

EVS 7010

Handleless built-in vacuum drawer, 14 cm high
for professional vacuum packing of food.



- Remains fresh for longer – storage and portioning of food
- Intense taste – marinating food
- Preparation of food for sous-vide cooking
- Easy handling – Touch controls and fully telescopic runners
- Opening the drawer couldn't be easier – Push2open

EAN: 4002516131618 / Material number: 11093430 / Old Material Number: 30701031GB

Construction type and design	
Built-in vacuum sealing drawer	•
VitroLine	•
ArtLine	•
Handleless	•
Operating modes	
Vacuum sealing	•
Convenience features	
Marinating food	•
Convenience features	
Food can be stored for longer	•
Preparing food for sous-vide cooking	•
Range of applications	
Vacuum sealing food	•
Vacuum sealing liquids	•
Vacuum sealing containers	•
Marinating food	•
Dividing food into portions	•
Resealing original packaging	•
Sealing jars	•
Design	
Colour	Graphite grey
User convenience	
Push2open mechanism	•
Fully telescopic runners for easy loading and unloading of the warming drawer	•
Control panel with sensor controls	•
Sealing duration settings	1 - 3
Control panel with symbols	•
Stop function	•
Vacuumping strength min. in steps	1
Max. vacuum settings	3
LED vacuum setting indicator	•
Vacuumping strength min. for external containers in steps	1
Max. vacuum settings for external containers	3
LED vacuum setting indicator	•
LED sealing duration indicator	•
Vacuum-sealing technology	
Stainless-steel vacuum chamber	•
Cleaning and care	
Flush control panel	•
Note regarding moisture removal from the vacuum pump	•
Replaceable sealing bar	•
Safety	
Safety switch-off	•
Technical data	
Appliance width in mm	595
Appliance height in mm	141

EVS 7010

Handleless built-in vacuum drawer, 14 cm high
for professional vacuum packing of food.



EAN: 4002516131618 / Material number: 11093430 / Old Material Number: 30701031GB

Appliance depth in mm	570
Useable interior height in mm	80
Total rated load in kW	0.32
Voltage in V	230
Frequency in Hz	50-60
Fuse rating in A	10
Number of phases	1
Mains cable with plug	•
Length of supply lead in m	1.8
User convenience	
Stainless steel vacuum sealing chamber capacity in l	8.0
Minimum bag size in mm	250
Maximum bag size in mm	350
Vacuum-sealing technology	
Pump capacity in m ³ /h	4
Accessories included	
Adapter for vacuum-sealing container	1
Vacuum sealing bag support	1
Vacuum sealing bags	•
Number of vacuum sealing bags 180 x 280 mm	50
Number of vacuum sealing bags 240 x 350 mm	50

EVS 7010

Handleless built-in vacuum drawer, 14 cm high for professional vacuum packing of food.

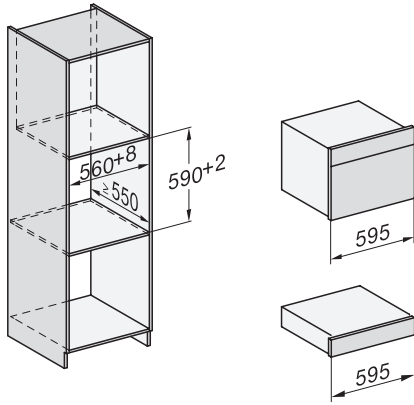

Installation_DG_DGM_DGC_XL_ESW7x10_EVS7010, installation drawings

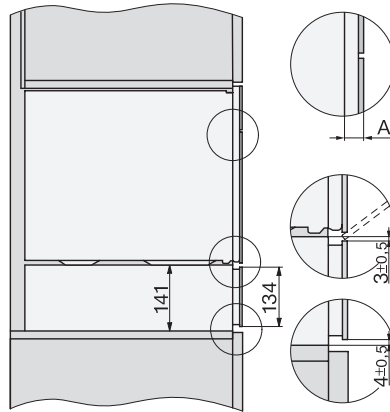

Side view_DG_DGM_ESW7x10_EVS7010 installation drawings

A) 22 mm glass, 23,3 mm stainless steel

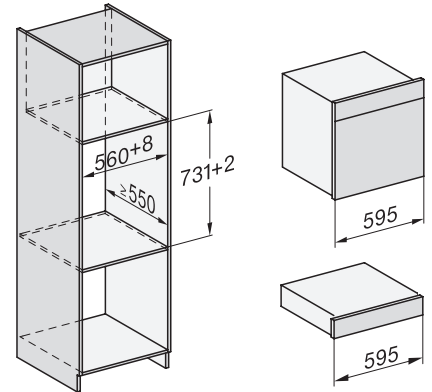

Installation_DGC_XXL_ESW7x10_EVS7010 installation drawings

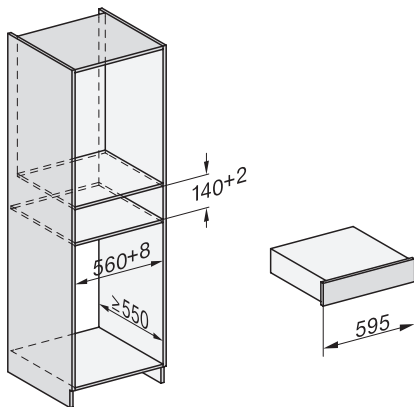

built-in ESW7x10 EVS7010, installation drawing

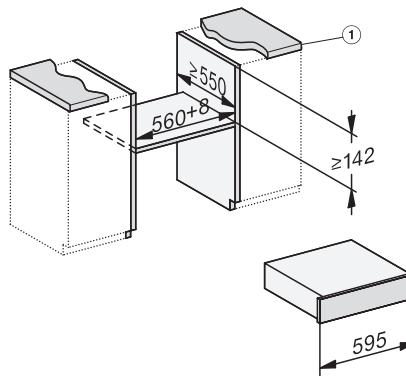

built-in EVS 7010 build-under, installation drawing

1) Countertop overhang ≤ 29mm

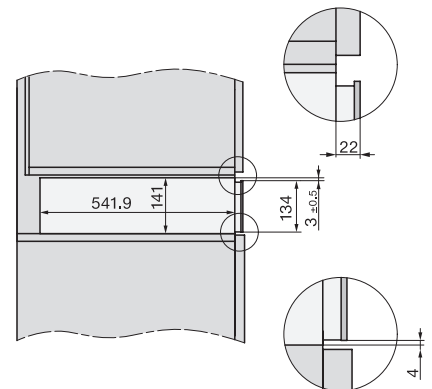

side view ESW7x10 EVS7010, installation drawing, GB, AU

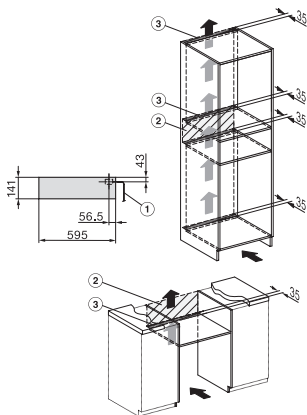

installation EVS7010 installation drawing, GB, AU

1) Mains connection cable, L=2000 mm, 2) No connection in this area, 3) Ventilation cutout min. 180 cm²