

DAD 6880 Levantar Ambient

Downdraft extractor

800 mm | 450 m³/h | 62.0 dB(a) | Touch | Con@ctivity | AmbientLight | ECO motor



- Easy recirculation mode installation with plug&play accessory set
- Motorised retractable deflector plate – Hood in Motion
- -
- AmbientLight# – individual, coloured lighting for an inviting atmosphere
- Efficient filtration- 10-ply stainless-steel grease filter



EAN: 4002516975090 / Material number: 12963340 /
Old Material Number: 28D6880BGB

General information	
Model identifier	DAD 6880 Levantar Ambient
Manufacturer material number	12963340
EAN number	4002516975090
Marketing class	Platinum
Construction type	
Downdraft extractor	•
Appliance type and design	
Appliance colour	Obsidian black
Operating modes	
Type of air guide	Can be retrofitted
Recirculation conversion kit (order separately)	DUU 600,DUP 150
Active charcoal filter (order separately)	DKF 30-P, DKF 30-R
Design	
Edge extraction	•
User convenience	
Miele@home	•
Electronic controls	•
Con@ctivity	Personalised
SmartControl White	•
Power levels (number without Booster level)	3
Run-on time 5/15 min.	•
Booster levels	2
Grease filter saturation indicator	•
Active charcoal filter saturation indicator	•
Motor-operated cooker hoods	•
Easy-to-clean canopy interior – CleanCover	•
Efficiency	
Energy efficiency class (A+++ – D)	A
ECO motor (DC motor)	•
PowerManagement system	•
Annual energy consumption in kWh/year	41.1
Fluid dynamic efficiency class	A
Lighting efficiency class	A
Grease filtering efficiency class	B
Filter system	
Number of dishwasher-safe stainless steel grease filters (10-ply)	2
Lighting	
Number x W	1x 12W + 1x 8W
Light intensity in lx	400 lx
Colour temperature in K	3500 Kelvin
Dimmer function	•
Ambient lighting colour	•
Fan	
Dual-action blower	•

DAD 6880 Levantar Ambient

Downdraft extractor

800 mm | 450 m³/h | 62.0 dB(a) | Touch | Con@ctivity | AmbientLight | ECO motor



EAN: 4002516975090 / Material number: 12963340 /

Old Material Number: 28D6880BGB

Exhaust air	
Air throughput in Level 1 (m ³ /h) according to EN 61591	205
Air throughput in Level 2 (m ³ /h) according to EN 61591	350
Air throughput in Level 3 (m ³ /h) according to EN 61591	450
Air throughput in Booster level 1 (m ³ /h) according to EN 61591	610
Air throughput in Booster level 2 (m ³ /h) according to EN 61591	655
Sound power in Level 1 (dB(A) re 1 pW) according to EN 60704-3	43.0
Sound power in Level 2 (dB(A) re 1 pW) according to EN 60704-3	55.0
Sound power in Level 3 (dB(A) re 1 pW) according to EN 60704-3	62.0
Sound power in Booster level 1 (dB(A) re 1 pW) acc. to EN 60704-3	69.0
Sound power in Booster level 2 (dB(A) re 1 pW) acc. to EN 60704-3	71.0
Sound pressure in Level 1 (dB(A) re 20 µPa) according to EN 60704-2-13	30.0
Sound pressure in Level 2 (dB(A) re 20 µPa) according to EN 60704-2-13	42.0
Sound pressure in Level 3 (dB(A) re 20 µPa) according to EN 60704-2-13	48.0
Sound pressure in Booster level 1 (dB(A) re 20 µPa) acc. to EN 60704-2-13	55.0
Sound pressure in Booster level 2 (dB(A) re 20 µPa) acc. to EN 60704-2-13	57.0
Recirculation	
Air throughput in Level 1 (m ³ /h) according to EN 61591	165
Air throughput in Level 2 (m ³ /h) according to EN 61591	320
Air throughput in Level 3 (m ³ /h) according to EN 61591	420
Air throughput in Booster level 1 (m ³ /h) according to EN 61591	525
Air throughput in Booster level 2 (m ³ /h) according to EN 61591	560
Sound power in Level 1 (dB(A) re 1 pW) according to EN 60704-3	49.0
Sound power in Level 2 (dB(A) re 1 pW) according to EN 60704-3	63.0
Sound power in Level 3 (dB(A) re 1 pW) according to EN 60704-3	69.0
Sound power in Booster level 1 (dB(A) re 1 pW) acc. to EN 60704-3	74.0
Sound power in Booster level 2 (dB(A) re 1 pW) acc. to EN 60704-3	75.0
Sound pressure in Level 1 (dB(A) re 20 µPa) according to EN 60704-2-13	36.0
Sound pressure in Level 2 (dB(A) re 20 µPa) according to EN 60704-2-13	50.0
Sound pressure in Level 3 (dB(A) re 20 µPa) according to EN 60704-2-13	55.0

DAD 6880 Levantar Ambient

Downdraft extractor

800 mm | 450 m³/h | 62.0 dB(a) | Touch | Con@ctivity | AmbientLight | ECO motor



EAN: 4002516975090 / Material number: 12963340 /

Old Material Number: 28D6880BGB

Sound pressure in Booster level 1 (dB(A) re 20 µPa) acc. to EN 60704-2-13 61.0

Sound pressure in Booster level 2 (dB(A) re 20 µPa) acc. to EN 60704-2-13 62.0

Safety

Safety switch-off •

Single-ply safety glass (ESG) •

Technical data

Canopy width in mm 800

Overall height for vented and external in in. (mm) 1008

Overall height for extraction mode and external mode cooker hoods in mm 1288

Canopy height in mm 708

Overall height for recirculation in in. (mm) 1008

Canopy depth in mm 171

Overall height for recirculation mode cooker hoods in mm 1288

Cut-out dimension in mm (width) with surface-mounted installation 790

Cut-out dimension in mm (depth) with surface-mounted installation 106

Cut-out dimension in mm (width) with flush-fit installation – internal 790

Cut-out dimension in mm (depth) with flush-fit installation – internal 106

Cut-out dimension in mm (width) with flush-fit installation – external 804

Cut-out dimension in mm (depth) with flush-fit installation – external 124

Net weight in kg 34.0

Length of supply lead in m 1.4

Standard plug fitted •

Installation on unit floor Yes

Installation on floor Yes

Min. base unit width in mm 900

Glass frame width in mm 800

Number of phases 1

Total rated load in kW 0.26

Voltage in V 230

Fuse rating in A 10

Frequency in Hz 50

Installation notes

Bottom exhaust duct •

Diameter of exhaust duct in mm 150

Optimum combination with hob subject to availability KM 8684 FL, KM 8685 FL

Joint installation with hob in one cut-out Yes

Flush-fit installation Yes

Surface-mounted installation Yes

DAD 6880 Levantar Ambient

Downdraft extractor

800 mm | 450 m³/h | 62.0 dB(a) | Touch | Con@ctivity | AmbientLight | ECO motor

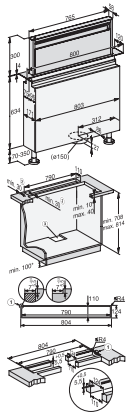

DAD4870, DAD6880, Installation drawings

1. Stepped cutout for flush-fit installation in stone worktops (granite, marble), 2. Ensure that materials are sufficiently stable, 3. Cut-out off-centre, Exhaust duct Ø 150 mm., *Only required when flat ducting is laid under cabinets or the DUU 600 recirculation box is used.

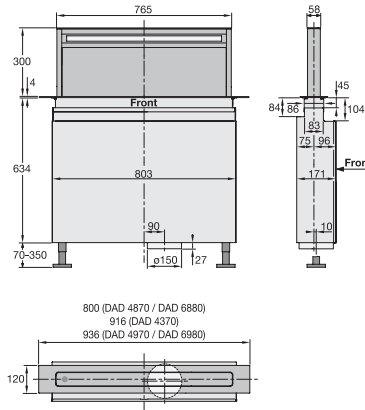

DAD4370, DAD4870, DAD4970, DAD6880, DAD6980, Installation drawings

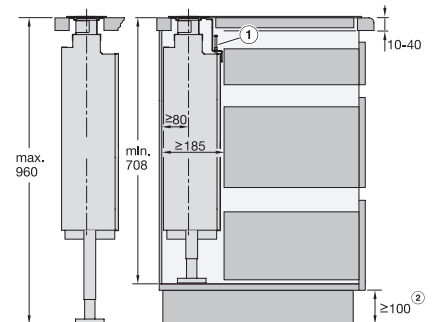

DAD4370, DAD4870, DAD4970, DAD6880, DAD6980, Installation drawings

1. If you install the extractor hood and hob flush with each other in a shared cut-out, you must use the angle strip provided., 2. The minimum dimension is required if flat ducts are installed under the cabinets or if the DUU 600 recirculation box is used.

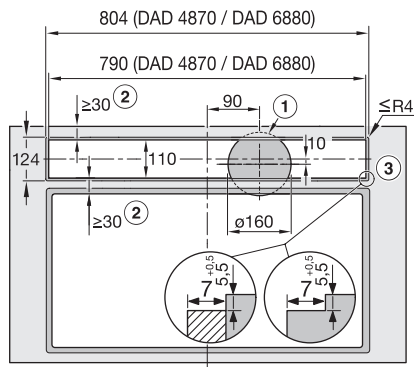

DAD4870, DAD6880, flush, Installation drawings

Installation of the downdraft hood and cooktop in separate cutouts., Flush installation., 1. Cut-out for exhaust air duct in the cabinet base., 2. Ensure sufficient stability of the worktop., 3. Step milling for flush mounting in a countertop. Note the, the different milling widths for the hob and the downdraft. Instead of a step milling, a wooden strip offset 5.5 mm downwards can be installed as an alternative (not included in the scope of delivery), , Exhaust air connection Ø 150 mm.

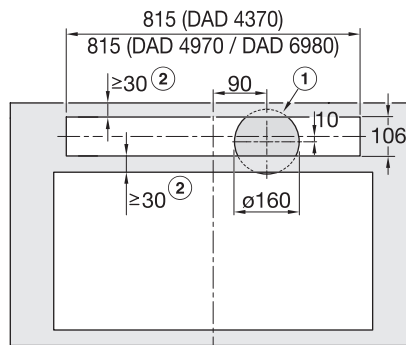

DAD4370, DAD4970, DAD6980, overlying, Installation drawings

Installation of the downdraft hood and cooktop in separate cutouts., Surface-mounted installation., 1. Cutout for exhaust air line in cabinet base., 2. Ensure sufficient stability of the worktop., Exhaust air connection Ø 150 mm

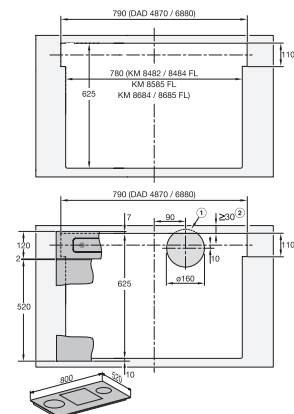

DAD4870, DAD6880, surface mounted installation, common cutout, Installation drawings

Side-by-side installation of the downdraft hood and the cooktop in a common cutout., Example: combination with KM 8684 FL or KM 8685 FL., Surface mounted installation., 1. Cut-out for exhaust air line in cabinet base., 2. Ensure sufficient stability of the worktop., , Exhaust air connection Ø 150 mm.

DAD 6880 Levantar Ambient

Downdraft extractor

800 mm | 450 m³/h | 62.0 dB(a) | Touch | Con@ctivity | AmbientLight | ECO motor

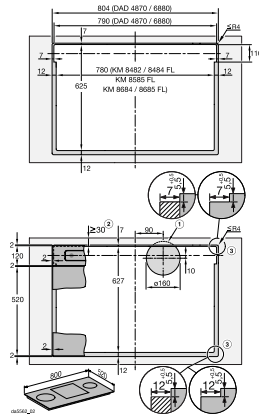

DAD4870, DAD6880, flush, Installation drawings

Side-by-side installation of the downdraft hood and the cooktop in a common cutout., Example: combination with KM 8684 FL or KM 8685 FL., Flush installation, 1. Cut-out for exhaust air duct in the cabinet base., 2. Ensure sufficient stability of the worktop., 3. Step milling for flush mounting in a worktop. Note the, the different milling widths for the hob and the downdraft ., Instead of a step milling, a 5.5 mm downwardly offset wooden strip can be installed (not included in the scope of delivery)., , Exhaust air connection \varnothing 150 mm.